



# Flexible Joint Robotic Manipulator Performance Improvement Using Mixed Synthesis Technique

Chioma V. Oleka <sup>a\*</sup>, K. A. Akpado <sup>a</sup> and Emmanuel C. Agbaraji <sup>b</sup>

<sup>a</sup> Electronics and Computer Engineering Department, Nnamdi Azikiwe University, Awka, Nigeria.

<sup>b</sup> Computer Engineering Department, Federal Polytechnic Nekede, Owerri, Nigeria.

## Authors' contributions

*This work was carried out in collaboration among all authors. All authors read and approved the final manuscript.*

## Article Information

DOI: 10.9734/JERR/2021/v21i1017494

## Open Peer Review History:

This journal follows the Advanced Open Peer Review policy. Identity of the Reviewers, Editor(s) and additional Reviewers, peer review comments, different versions of the manuscript, comments of the editors, etc are available here: <https://www.sdiarticle5.com/review-history/81018>

**Original Research Article**

**Received 20 October 2021**  
**Accepted 22 December 2021**  
**Published 23 December 2021**

## ABSTRACT

The flexible joint robot is gaining more popularity in research and development because of its light weight and numerous applications. The major problems of the flexible joint robotic manipulator are poor tracking performance and instability. This work aims at improving the tracking performance and stability of the flexible joint robot based on the tracking error, damping time, overshoot and stability margins of the flexible joint model. To achieve this, a mixed synthesis method was applied. The mixed sensitivity synthesis is a robust control technique which uses adjustable weights to design a robust controller model which improves the performance and stability of a plant through loop shaping. From the results, the flexible joint model recorded damping time of infinity which is very high, gain margin of 22.8dB and very low phase margin of 3.21e-12deg. This means that the flexible joint model suffers from poor performance and it is unstable. The mixed synthesis controlled flexible joint model recorded low damping time of 0.993seconds, overshoot of 0%, tracking error of 0.0214dB, gain margin of 24.9dB and phase margin of 86.9degrees. This means that the mixed sensitivity synthesis controlled FJR achieved improved tracking performance and robust stability. The mixed synthesis control technique maintained negligible changes in damping time, tracking error and stability margins when the joint flexibility coefficient of the joint was varied to verify the robustness of the system. The work concludes that the flexible joint tracking performance and stability improvement was achieved using mixed sensitivity synthesis.

**Keywords:** Flexible joint robot; robotic manipulator; mixed sensitivity synthesis; tracking performance; robust stability.

## 1. INTRODUCTION

The desire for higher performance from the structure and mechanical specifications of robot manipulators has spurred designers to come up with flexible joint robots (FJR) [1]. Energy is the ultimate handicap for both rigid and flexible joint robot manipulators as well as controllers. Robots must have higher efficiency to work and also for mobile robots to use battery. Energy utilization from the battery effects operating time of mobile robot. Thus, a poor performing robot consumes more energy thereby shortens the operating time of the robot. To improve the performance of the manipulator, a controller function needs be designed for the particular robot model. Hence, with an adequately controlled flexible robot, the problem of faster battery energy consumption will be solved. Spring energy which is stored in flexible joints helps system for power needs [2]. This means that the flexible joint adds more degree of freedom and functions with less energy consumption more especially when it is adequately controlled. From the review, the control and preference of flexible robots is increasing [3].

Flexible joint robots are recently being applied more in the industries due to their numerous advantages over the rigid robots. They are applied in most fields where performance and high accuracy are needed such as in the space robot [4]. However, compared with rigid robots, number of degrees of freedom becomes twice as number of control actions due to flexibility in the joints, and the matching property between nonlinearities and inputs is lost [5]. Performing high-precision applications by a flexible joint robot seems to be difficult since the link position cannot directly follow the actuator position. As a result, the flexibility in joints should be compensated or controlled to improve the performance and avoid unwanted oscillations.

The flexible-joint robot manipulator particularly presents serious problems such as nonlinearity, largeness of model, coupling, uncertainty, and joint flexibility in the modeling and control [6] which affect its tracking performance. To address this problem, much research interest has been attracted especially in the areas of control of the tracking performance [7-9] and stability of the robotic manipulators. Many works have been carried out for the performance improvement of the flexible joint robot, such as Proportional Derivative (PD) control in [10], singular perturbation theory in [11], robust control in [12],

sliding mode control in [13], adaptive control in [14], fuzzy control in [15] and state observer-based control [16]. However, while most of these advanced control methods have been proposed, few such as the robust, adaptive, state observer etc. have been confirmed to be more effective due to their robustness properties and design characteristics. Mixed Sensitivity (MS) Synthesis is one of the robust controller design techniques that make use of weights to augment the plant for a controller design through loop shaping based on robustness specifications. It can handle single input and single output (SISO) systems likewise multiple input and multiple output (MIMO) systems.

## 2. LITERATURE REVIEW

### 2.1 Flexible Joint Robot Model

Despite its numerous advantages, the flexibility property of the flexible joint robotic manipulators has been considered a common problem which can affect the performance of the robotic system if not taken into consideration during the design stage. Due to this problem, several dynamic models have been proposed for the flexible joint robot. While some of the researchers considered only the mechanical arm dynamics and ignore the actuator dynamics, some others considered the features of the actuators including the gear dynamics in the models. Moberg [17] presented an elastic model of the flexible robot manipulator he termed, lumped parameter model. Considering the robotic manipulator with elastic gearboxes, i.e., elastic joints; this robot can be modeled by the so called flexible joint model which is illustrated in Fig. 1. The rigid bodies are connected by torsional spring-damper pairs.

### 2.2 Theory of Mixed Sensitivity Synthesis (Mixed synthesis)

Mixed synthesis is a robust controller design method which depends on the weights in order to generate desired control signal to control a plant. The design of a control system using mixed synthesis amounts to the shaping of its sensitivity functions to achieve the design targets of the closed-loop system performance and robustness. It was applied mostly in areas where control of the plant is very difficult either due to model uncertainties or high level of disturbances. Solving the mixed sensitivity problem of the sensitivity  $S$  over  $KS$  problem is defined by a general relation for the Single Input Single Output (SISO) system.

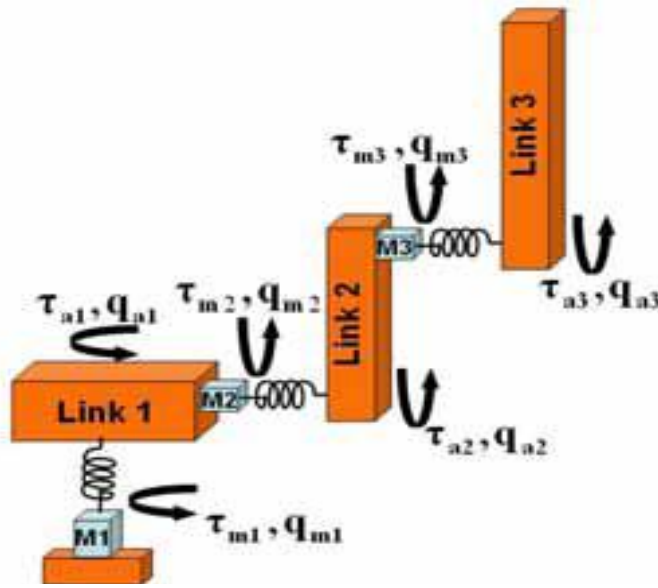

Fig. 1. A flexible joint dynamic model with 6 DOF [17]

$$\min_{Kst} \left\| \frac{S(s)}{K(s)S(s)} \right\|_{\infty} = \min_{Kst} \left\| \frac{[1 + L(s)]^{-1}}{K(s)[1 + L(s)]^{-1}} \right\|_{\infty} \quad (1)$$

$$S = (1 + L)^{-1} \quad (4)$$

Where  $K$  is the controller to be designed,  $L$  is the open loop gain.

The open-loop function is equal to  $L = K \times G$ , where  $K$  is the controller and  $G$  is the plant.

In the case of optimal robust control the problem is to find a controller  $K$  that fulfills the following condition [18]:

$$\|F(P, K)\|_{\infty} < \gamma \quad (2)$$

### 3. METHODOLOGY

The optimization factor  $\gamma$ , augmented model  $P$  and robust controller  $K$ , the mixed-synthesis algorithm search is based on the iteration procedure. After performed analysis of the singular value  $\sigma$  of the closed-loop function  $T$  the mixed-controller should pass the condition in the frequency domain [18]:

The flexible joint robotic manipulator dynamic model is an elastic, lumped parameter model with elastic gearboxes, i.e., elastic joints. The rigid bodies are connected by torsional spring-damper pairs. If the inertial couplings between the motors and the rigid links are neglected, the simplified flexible joint model was gotten. If the gear ratio is high, this is a reasonable approximation as described in [12]. The motor mass and inertia are added to the corresponding rigid body.

$$\sup_{\omega \in R} \sigma_{max}(T(j\omega)) \leq 1 \quad (3)$$

The model equations of the simplified flexible joint model are:

The robust controller involves the plant model and the weighting functions. Two weighting functions are designed to shape performance of the closed loop system. The weighting function  $W1$  was put on the error signal from the difference between the actual output and desired input and  $W2$  was put on the control signal. The design process of weighting functions was described in [19]. The mixed-controller was computed by function *mixsyn* provided by Robust Control Toolbox [20]. Quality of the vibration control is evaluated by using sensitivity function which is given by [21]:

$$M_a(q_a)\ddot{q}_a + c(q_a, \dot{q}_a) + g(q_a) = \tau_a \quad (5)$$

$$\tau_a = k(q_m - q_a) + D(\dot{q}_m - \dot{q}_a) \quad (6)$$

$$\tau_m - \tau_a = M_m\ddot{q}_m + f(\dot{q}_m) \quad (7)$$

where joint and motor angular positions are denoted by  $q_a \in \mathbb{R}^N$  and  $q_m \in \mathbb{R}^N$  respectively.  $\tau_m$  is the motor torque and  $\tau_a$  is the gearbox output torque.  $k \in \mathbb{R}^{N \times N}$  is a stiffness matrix and  $D \in \mathbb{R}^{N \times N}$  is the matrix of dampers.  $M_a$  and  $M_m$  are the joint and motor inertia matrices. A vector of friction torque was introduced into the model

and described by  $f(\dot{q}_m) \in \mathbb{R}^N$ . The friction torque is here approximated as acting on the motor side only.

In robotic applications, the joint flexibility cannot be neglected and the joint flexibility of the flexible joint robot can cause poorly damped oscillations. Thus, the joint flexibility should be taken into account in any flexible joint robotic modeling. Considering the robotic link rotating on a horizontal plane and actuated with a motor through elastic joint coupling as shown in Fig. 2. Let  $q_a$  be the link angular displacement and  $q_m$  be the motor angular position. Typical flexible joint robotic arm dynamic model can be

described by the dynamic equations as presented as follows:

$$J_a \ddot{q}_a + Mgl \sin(q_a) + k(q_a - q_m) = 0 \quad (8)$$

$$J_m \ddot{q}_m + k(q_a - q_m) = \tau \quad (9)$$

The transfer function, in s-domain, of the system is given as follows:

$$G(s) = \frac{k}{J_a J_m s^4 + (J_a k + Mgl J_m + k J_m) s^2 + Mgl k} \quad (10)$$

The controller design for the tracking performance improvement of the flexible joint robot involves feedback mechanism as shown in Fig. 3.

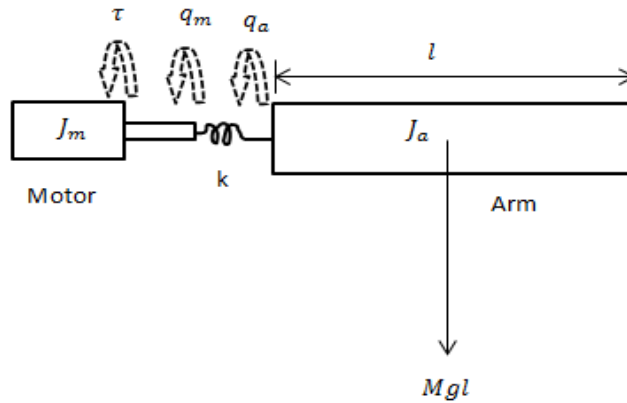

Fig. 2. Flexible joint model of the manipulator

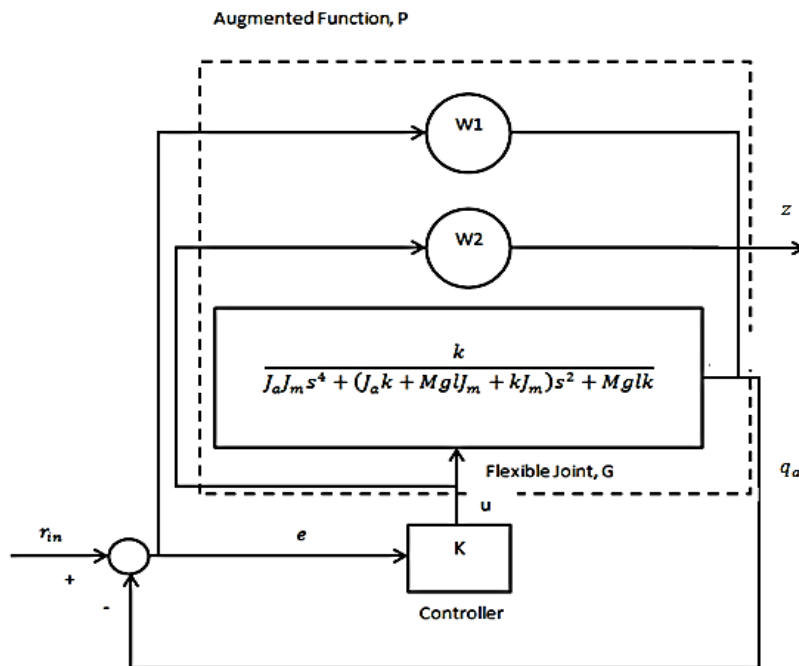

Fig. 3. Controlled system with the augmented function

**Table 1. Flexible joint parameters [22]**

Symbol	Description	Value
$J_a$	Inertia of flexible joint robotic manipulator	0.03kgm <sup>2</sup>
$J_m$	Inertia of the flexible joint actuator	0.004kgm <sup>2</sup>
$g$	Gravitational acceleration	9.81N/m
$l$	Distance to center of gravity of the manipulator rotational link	0.135m
$M$	Mass of the link	0.6kg
$k$	Flexibility coefficient of the joint	31.0Nm/rad

The design objectives for robustness characteristics are [23, 24]:

- i. To reduce the tracking error to value close to zero
- ii. To reduce the damping time to value less than one
- iii. To increase the gain margin to greater than or equal to 20dB
- iv. To increase the phase margin to greater than or equal to 60deg

### 3.1 The Mixed Sensitivity Synthesis Algorithm

The mixed-synthesis algorithm is presented as follows:

- i. Apply flexible joint transfer function  $G$ ,
- ii. Apply the weighting functions  $W1(s)$  and  $W2(s)$  on the flexible joint transfer function  $G(s)$
- iii. Form the augmented function  $P(s)$  with  $G(s)$ ,  $W1(s)$  and  $W2(s)$  using MATLAB operator, `aug`:

$$P(s) = \text{aug}(Gp, W1, W2) \quad (11)$$

- iv. Generate the controller  $K$  in state space using the `mixsyn` syntax in MATLAB that can improve the output of the system and satisfy the desired characteristics:

$$[K] = \text{mixsyn}(P) \quad (12)$$

- v. Compute the open loop gain function:

$$L = K \times G \quad (13)$$

- vi. Compute the improved flexible joint function  $T(s)$ :

$$T(s) = \frac{K.k}{J_a J_m s^4 + (J_a k + M g l J_m + k J_m) s^2 + M g l k + K.k} \quad (14)$$

- vii. Plot a time domain graph for the existing flexible joint model function  $G(s)$  to determine the damping time.
- viii. Plot a time domain graph for the mixed synthesis controlled flexible joint model function  $T(s)$  to determine damping time.
- ix. Plot a frequency domain graph for the mixed synthesis controlled flexible joint model function  $T(s)$  to determine the tracking error.
- x. Plot a frequency domain graph for the open loop function  $L(s)$  to determine the stability of the mixed synthesis controlled flexible joint model.

## 4. RESULTS AND DISCUSSION

In Fig. 4, the damping time is at infinity and this means that the system did not settle or was not damped properly and it is continuously vibrating.

From Fig. 5, gain margin of 22.8dB, phase margin of 3.21e-12 deg were recorded and the system was unstable. Table 2 shows the results o the FJR model analysis.

**Table 2. Summary of the FJR model analysis results**

Characteristics	FJR Model
Damping Time (Seconds)	Infinity
Overshoot (%)	0
Gain Margin (dB)	22.8
Phase Margin (Deg)	3.21e-12
Stability	Unstable

The results in Table 2 show that the flexible joint model is unstable therefore it requires adequate damping technique and robust control measure to improve its performance and stability.

The controller design results for the flexible joint robot using mixed sensitivity synthesis are presented as shown in Figs 6, 7 and 8. Table 3 shows the mixed synthesis controlled FJR model performance and stability analyses.

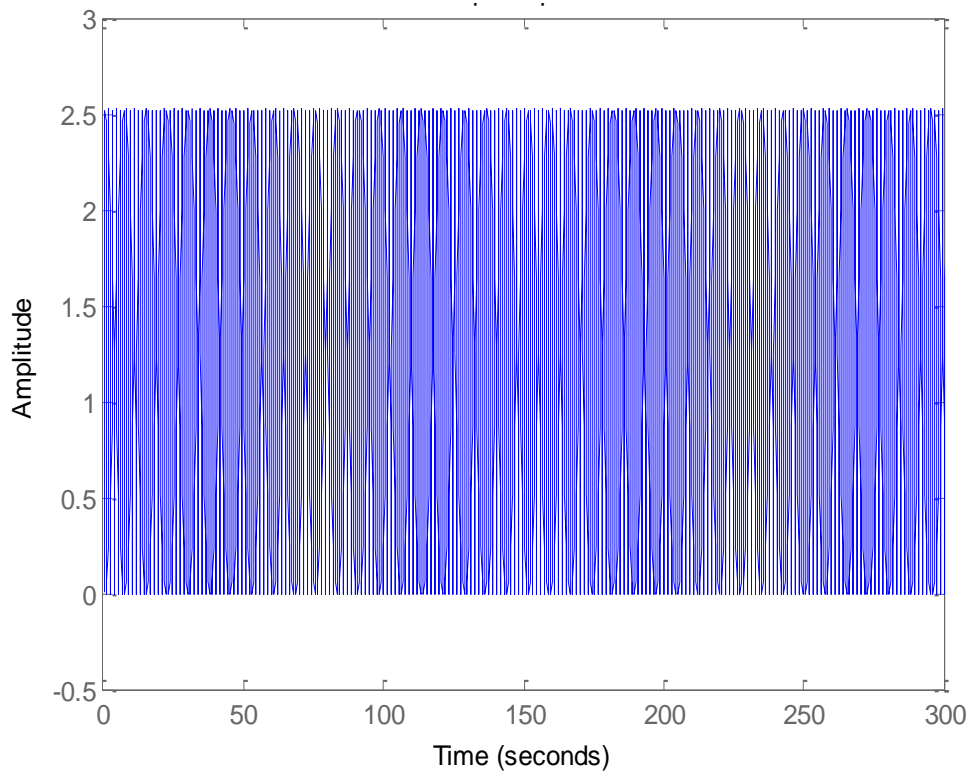

**Fig. 4. Damping time for the existing flexible joint**

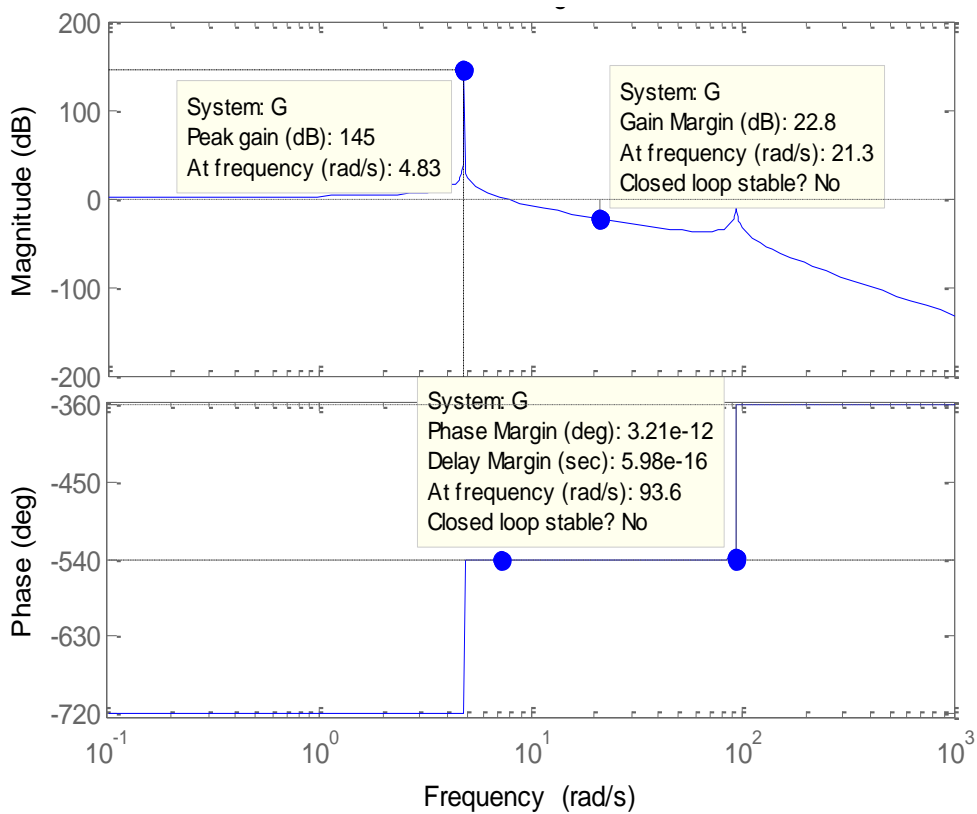

**Fig. 5. The stability margin graphs for the existing flexible joint**

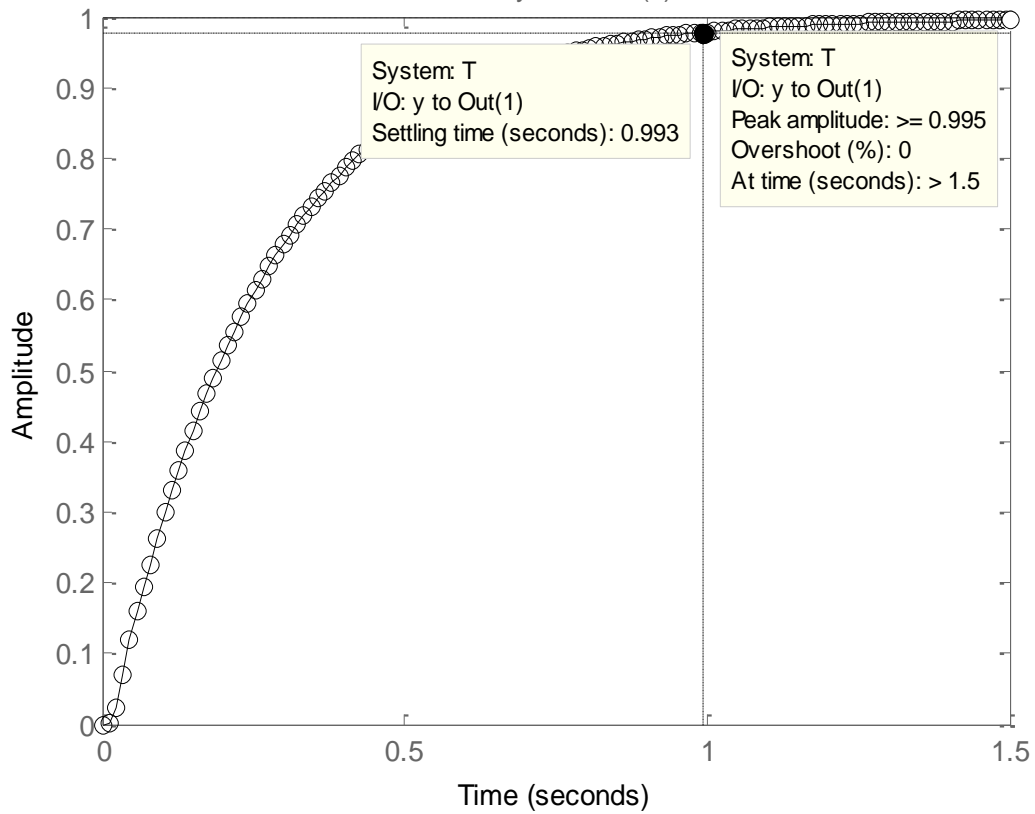

**Fig. 6. Step response of the mixed synthesis controlled flexible joint model**

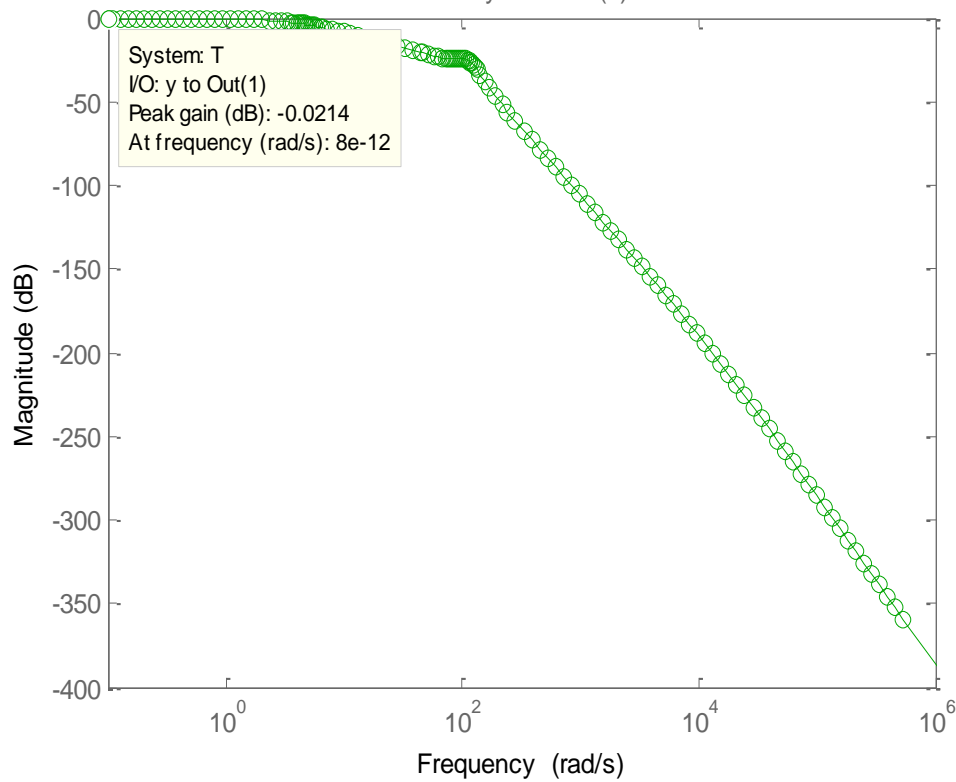

**Fig. 7. Tracking performance of the improved flexible joint**

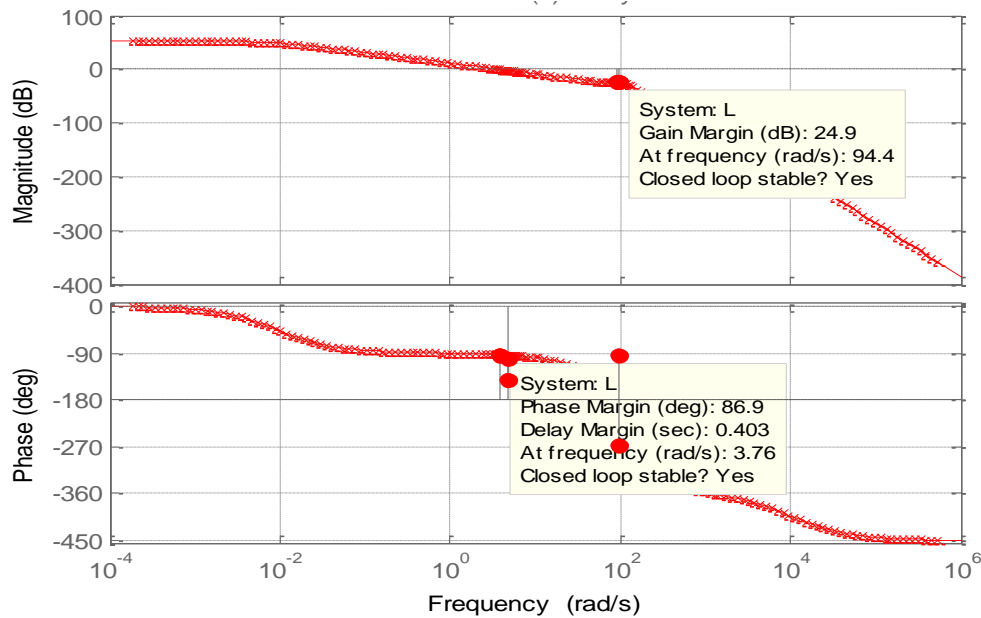

**Fig. 8. Stability margin plot of the improved flexible joint**

Continuous-time state-space model of the developed controller K is as follows:

$$\begin{aligned} \dot{x} &= Ax + Bu \\ y &= Cx + Du \end{aligned} \tag{11}$$

$$A = \begin{bmatrix} -1.086e + 04 & -1.153e + 04 & -1.895e + 05 & -7.963e + 05 & 1.899e + 05 \\ 128 & 5.821e - 11 & 0 & 3.097e - 08 & 6.98e - 15 \\ 0 & 8 & 5.821e - 11 & 1.19e - 12 & 2.638e - 17 \\ 0 & 0 & 16 & -6.257e - 10 & -1.541e - 16 \\ 0 & 0 & 0 & -1.577e - 05 & -0.009262 \end{bmatrix}$$

$$B = \begin{bmatrix} -2.037e - 12 \\ 6.173e - 09 \\ 2.373e - 13 \\ -1.363e - 10 \\ 3.144 \end{bmatrix}, C = [-3454 \quad -3646 \quad -6.03e + 04 \quad -2.533e + 05 \quad 6.043e + 04] \quad D = [0]$$

**Table 3. Summary of the mixed synthesis controlled FJR model analysis results**

Characteristics	Mixed-synthesis controlled FJR
Damping Time (Seconds)	0.993
Overshoot (%)	0
Tracking Error (dB)	0.0214
Gain Margin (dB)	24.9
Phase Margin (Deg)	86.9
Stability	Stable

The results in Table 3 show that the mixed synthesis controlled flexible joint model recorded 0.993seconds settling time and 0% overshoot. It also recorded 0.0214dB tracking error which is not significant, gain margin of 24.9dB and phase margin of 86.9deg. These show that the mixed synthesis controlled flexible joint model achieved the desired improvement since it met the specified design objectives.

## 5. CONCLUSION

The damping time of the flexible joint model was at infinity and this means that the system did not settle and it is continuously vibrating. As a result, the flexible joint will keep vibrating until it heats up and break down. Gain margin of 22.8dB and phase margin of 3.21e-12 deg were recorded and the system was unstable.



Applying mixed synthesis, the flexible joint robot achieved damping time of 0.993seconds. This means that it takes the joint 0.993 seconds to achieve its equilibrium or settle back to its normal function after encountering disturbance. The oscillation at the joint has been cancelled and the joint can function optimally for a long time without experiencing a drop in its performance level. The mixed synthesis controlled flexible joint achieved tracking error of 0.0214dB. This indicates that the difference between the actual output and the desired output is 0.0214dB, which is very low and negligible. The mixed sensitivity synthesis controller achieved gain margin of 24.9dB and phase margin is 86.9degrees. The results satisfy robustness characteristics of performance and stability. Hence, the mixed synthesis controlled flexible joint model can withstand disturbance and maintain its optimal performance in the presence of disturbance.

### COMPETING INTERESTS

Authors have declared that no competing interests exist.

### REFERENCES

- Ozgoli S, Taghirad HD. A Survey on the Control of Flexible Joint Robots, *Asian Journal of Control*. 2006;8(4):332-344.
- Müderrisoğlu K, Ömürlü VE. 3rd International Scientific Conference on Engineering, Manufacturing and Advanced Technologies;2014.
- Li T, Zhang J, Zhang Y. Equilibrium Configurations of a Planar 3-DOF Parallel Robot with Flexible Joints, 6th World Congress on Intelligent Control and Automation, Dalian, China;2006.
- Ulrich S, Sasiadek JZ. On the Simple Adaptive Control of Flexible-Joint Space Manipulators with Uncertainties, *Aerospace Robotics II, Geo Planet: Earth and Planetary Sciences*, Springer International Publishing Switzerland. 2015; 13-23.
- Brogliato B, Ortega R, Lozano R. Global tracking controllers for flexible-joint manipulators: A comparative study, *Automatica*. 1995;31(7):41–956.
- Fateh MM. Robust control of flexible-joint robots using voltage control strategy, Springer Science Business Media, *Nonlinear Dyn*. 2012;67:1525–1537
- Dachang Z, Baolin D, Puchen Z, Wu W. Adaptive Backstepping sliding mode control of trajectory tracking for robotic manipulators. *Hindawi Complexity*. 2020;2020:1-11
- Zhang Y, Qiao G, Song G, Song A. and Wen X. Experimental Analysis on the Effectiveness of Kinematic Error Compensation Methods for Serial Industrial Robots, *Hindawi Mathematical Problems in Engineering*. 2021;2021:1-9.
- Iskanderani AM, Mehedi IM. Experimental Application of Robust and Converse Dynamic Control for Rotary Flexible Joint Manipulator System, *Mathematical Problems in Engineering*. 2021;2021:1-9.
- Tomei P. A simple PD controller for robots with elastic joints. *IEEE Trans. Automat. Contr*. 1991;36(10):1208-1213.
- Marino R, Nicosia S. Singular perturbation techniques in the adaptive control of elastic robots, In: *The IFAC Symp. Robot Contr.*, Barcelona, Spain;1985.
- Spong MW. Modeling and control of elastic joint robots, *ASME J Dyn Syst Meas Control*. 1987;109(4):310–319
- Wilson GA. Robust tracking of elastic joint manipulators using sliding mode control, *Trans. Inst. Meas. Control*. 1994;16(2):99–107.
- Spong MW. Adaptive control of flexible joint manipulators: comments on two papers, *Automatica*. 1985;31(4):585–590.
- Chang LL, Chuan CC. Rigid model-based fuzzy control of flexible-joint manipulators, *J. Intell. Robot. Syst*. 1995;13(2):107–126.
- Talole E, Kolhe P, Phadke B. Extended state observer based control of flexible joint system with experimental validation, *IEEE Trans. Ind. Electron*;2009.
- Moberg S. Modeling and Control of Flexible Manipulators, *Linköping Studies in Science and Technology*, Sweden;2010.
- Zhou K, Doyle JC. *Essentials of Robust Control*, Prentice Hall;1997.
- Gosiewski Z, Mystkowski A. Robust control of active magnetic suspension: analytical and experimental results. *Mechanical Systems & Signal Processing*. 2008;22 (6):1297-1303.
- Math Works. *Robust Control Toolbox User's Manual*, 3rd ed;2004.
- Mystkowski A. Sensitivity and Stability Analysis of Mu-synthesis AMB Flexible Rotor, *Solid State Phenomena*. 2010; 164:313-318.

22. Adel M, Jason G. Generalized Predictive Control for Single-Link Flexible Joint Robot, international Journal of Sciences and Techniques of Automatic Control & Computer engineering, IJ-STA. 2009; 3(1):890-899.
23. Agbaraji EC. Robustness Analysis of a Closed-loop Controller for a Robot Manipulator in Real Environments, Physical Science International Journal. 2015;8(3):1-11.
24. Agbaraji EC, Udeani UH, Inyama HC, Okezie CC. Robust Control for a 3DOF Articulated Robotic Manipulator Joint Torque under Uncertainties, Journal of Engineering Research and Reports. 2020; 9(4):1-13.

---

© 2021 Oleka et al.; This is an Open Access article distributed under the terms of the Creative Commons Attribution License (<http://creativecommons.org/licenses/by/4.0>), which permits unrestricted use, distribution, and reproduction in any medium, provided the original work is properly cited.

*Peer-review history:*  
*The peer review history for this paper can be accessed here:*  
<https://www.sdiarticle5.com/review-history/81018>